

# safeCAP SC4

## Original operating instructions

---

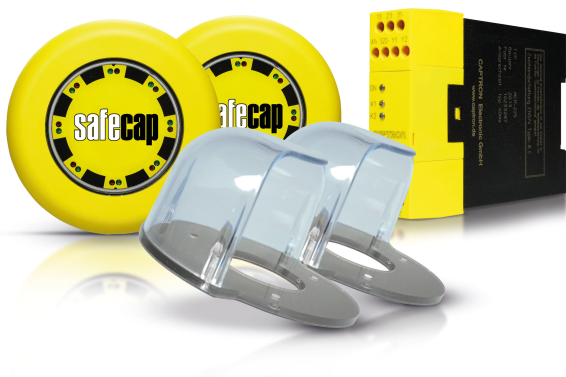

*safeCAP SC4 with MCR-225*

## Table of Contents

<b>1 Foreword</b> .....	<b>4</b>
<b>2 Safety</b> .....	<b>4</b>
2.1 Notes and symbols used.....	4
2.2 General safety.....	5
2.3 Personnel qualifications.....	5
2.4 Intended use.....	6
2.5 Reasonably foreseeable misuse.....	6
2.6 Determining the lifetime and validating the entire system.....	6
2.7 Example calculation.....	6
2.8 Equivalent T-network.....	7
<b>3 General description</b> .....	<b>8</b>
3.1 safeCAP SC4.....	8
3.2 Operating states.....	8
<b>4 Storage</b> .....	<b>9</b>
<b>5 Assembly</b> .....	<b>9</b>
5.1 Prepare SC4 for assembly.....	10
5.2 Recommended screw types.....	10
5.3 Maximum dimensions of the screws.....	10
5.4 SC4 assembly without SCP4.....	11
5.5 Connecting SC4 to the safety relay.....	12
5.5.1 MCR-225 connection plan.....	12
5.5.2 Connecting SC4 to a spare safety relay.....	12
5.6 Testing the safety function of the SC4.....	12
<b>6 Maintenance</b> .....	<b>13</b>
6.1 Maintenance operations.....	13
<b>7 Disposal</b> .....	<b>14</b>
<b>8 Technical specifications</b> .....	<b>14</b>
8.1 Technical specifications, safety relay MCR-225.....	15

8.2	Dimensional drawing.....	16
8.2.1	SC4A.....	16
8.2.2	SC4B.....	17
<b>9</b>	<b>Declaration of conformity.....</b>	<b>18</b>
<b>10</b>	<b>Imprint.....</b>	<b>19</b>

# 1 Foreword

These operating instructions are intended for installers and operators and should be kept for future reference. Read these operating instructions carefully and make sure that you have fully understood the contents before installing or working with the safeCAP SC4. The operator is responsible for validating the entire safety system.

## 2 Safety

### 2.1 Notes and symbols used

Warning notes in relation to personal injury / material damage are formulated according to the "SAFE" principle. This means they contain information on the type and source of the hazard, potential consequences as well as how to avoid and avert danger. The following hazard classifications apply in the safety notes:



Danger designates a hazardous situation, which, if ignored, will lead to death or serious injury. The symbol next to the warning indicates the type and source of the danger.



Warning designates a hazardous situation, which, if ignored, may lead to death or serious injury. The symbol next to the warning indicates the type and source of the danger.



Caution designates a hazardous situation, which, if ignored, may lead to injury. The symbol next to the warning indicates the type and source of the danger.



Notice designates a situation, which may cause material damages and impair the product's function if attention is not paid.

## TIP

Tip provides additional useful information about the handling of the product.

Symbol	Meaning
▸	Avoiding and adverting danger in the warning note
▶	Instructions for action All instructions to be followed within a procedure are always listed in chronological order.
▪	List

## 2.2 General safety

All work on electrical systems or operating equipment may only be carried out by a specially qualified electrician according to the applicable electrotechnical regulations.

The safety of the system in which the SENSORswitch is integrated is the responsibility of the operator.

## 2.3 Personnel qualifications

A qualified electrician is a person with suitable technical training, expertise and experience as well as knowledge of relevant standards, who can evaluate the work assigned to them correspondingly and recognize potential risks.

The following general safety notes for working with electrical energy must be observed:

### WARNING

#### **Improper work on electrical systems!**

Electric shock can result in death or life-threatening injuries.

- Before working on electrical systems, disconnect them from their voltage supply and secure them against being switched on again.
- Wear appropriate personal protective equipment (PPE).
- Defects that are ascertained, such as damaged or loose cables, must be remedied immediately.

## 2.4 Intended use

Combined with safety relay MCR-225, safeCAP SC4 ensures safety-related release and interruption of a safety circuit. safeCAP SC4 is used to protect people from work machines with dangerous closing movements. If safeCAP SC4 is used without the aforementioned safety relay, the operator is responsible for safety-related release and interruption of the safety circuit.

## 2.5 Reasonably foreseeable misuse

Any use other than as specified in the section [Intended use](#) or extending beyond this is deemed to be improper.

The switch is not suitable for:

- use as a two-hand control without the aforementioned relay or independent calculation of the performance level in accordance with ISO 13849.
- use as a two-hand control without validation of the entire system.
- use as an emergency stop command device.
- use in potentially explosive atmospheres.
- use outdoors.

## 2.6 Determining the lifetime and validating the entire system

The following steps are mandatory.

- Determine the real parameters of the system.
  - Required performance level
  - $d_{op}$
  - $h_{op}$
  - $t_{cycle}$
- The operator must verify that the lifetime  $T_M$  is not exceeded.
- Validate the entire system.
- Observe the safety considerations in the operating instructions of the safety relay.

## 2.7 Example calculation

The following values are only examples and must be replaced with your own values.

- Performance level e must be achieved.
- $d_{op} = 250$  d
- $h_{op} = 24$  h
- $t_{cycle} = 10$  s

$n_{op}$  [cycles / year]

$$n_{op} = (d_{op} * h_{op} * 3600 \text{ s}) / t_{cycle}$$

$$n_{op} = 250 \text{ d} / \text{y} * 24 \text{ h} / \text{d} * 3600 \text{ s} / \text{h} / 10 \text{ s} / \text{cycle} = 2,160,000 \text{ cycles} / \text{year}$$

According to the operating instructions, the relay has a lifetime of approximately 20 million cycles before a dangerous failure can occur.

$$T_M = 20,000,000 / n_{op}$$

$$T_M = 20,000,000 / 2,160,000 = 9.3 \text{ years}$$

According to this calculation, the relay has to be replaced after 9.3 years.

For other relays, values such as  $B_{10D}$  or  $T_{10D}$  can be specified. These values are not considered here and can be requested from CAPTRON.

## 2.8 Equivalent T-network

If an equivalent T-network is used for the relay, the entire FIT value for the equivalent T-network must be determined via an FMEDA or an equivalent method.

The equivalent T-network must not exceed a FIT value of 45, and the  $MTTF_d$  should be more than 45 years to meet the following formula:

$$MTTF_d \text{ (Equivalent t-network)} = MTTF_d \text{ (safeCAP)} * 30 / (MTTF_d \text{ (safeCAP)} - 30).$$

Exception:  $MTTF_d \text{ (safeCAP)} = 100$ ;

### 3 General description

#### 3.1 safeCAP SC4

- 1 Colored cover ring
- 2 LEDs
- 3 Button surface



#### 3.2 Operating states

The LEDs indicate the different operating states of the SC4.

	<p>Green LEDs lit up.</p>	<p>SC4 is ready for operation.</p>
	<p>Red LEDs lit up.</p>	<p>Button surface being actuated.</p>
	<p>Green LEDs lit up. Red LEDs flashing.</p>	<p>SC4 not working</p> <ul style="list-style-type: none"> <li>▪ Insufficient actuation speed</li> <li>▪ The button surface is excessively dirty or wet</li> <li>▪ There are objects on the button surface</li> </ul>

## 4 Storage

Component	Conditions
safeCAP SC4	-25°C (-13°F) to 75°C (167°F)
Safety relay	-40°C (-40°F) to 85°C (185°F)
Protector SCP-4	Protected against UV light for max. two years 20°C (68°F) 50% -70% relative air humidity

## 5 Assembly

### WARNING

#### Improper work on electrical systems!

Electric shock can result in death or life-threatening injuries.

- ▶ Before working on electrical systems, disconnect them from their voltage supply and secure them against being switched on again.
- ▶ Work on electrical installations should be carried out only by qualified personnel in compliance with local and national electrical regulations and specifications.

### WARNING

#### Improper safeCAP SC4 assembly!

An improperly assembled two-hand control device can result in death or life-threatening injuries.

- ▶ Select mounting surfaces for the safeCAP SC4 based on the dimensions and spacing specified in DIN EN ISO 13851.
- ▶ Protect safeCAP SC4 against unintended actuation, for example SCP-4.
- ▶ Before working on the machine, check safeCAP SC4 for proper function.

## 5.1 Prepare SC4 for assembly

Requirements: Mounting surface is level and clean.

- ▶ Disconnect the system from its voltage supply and secure it against being switched on again.
- ▶ Set the desired position of the SC4 and provide a center hole of minimum  $\varnothing$  45 mm to maximum  $\varnothing$  60 mm.
- ▶ Position the SC4 (B), lining up the center and vertical axis, and mark the holes (C).
- ▶ Select the diameter of the holes according to the recommended screw type and start drilling.
- ▶ Depending on the installation position, you now need to connect the SC4. [see "Connecting SC4 to the safety relay"](#)

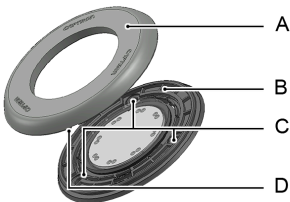

## 5.2 Recommended screw types

- DIN EN ISO 1207 M4
- DIN EN ISO 7045 M4
- DIN EN ISO 1481  $\varnothing$ 3.9 mm
- DIN EN ISO 7049  $\varnothing$ 3.9 mm

## 5.3 Maximum dimensions of the screws

The drawing shows the maximum dimensions of the screws.

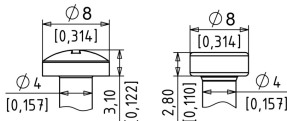

## 5.4 SC4 assembly without SCP4

Requirements: Mounting surface is level and clean.

### NOTICE

#### Risk of damage to the mounting flange!

Unsuitable screw heads or too great a tightening torque for the screws can damage the mounting flange.

- ▶ Do not use countersunk screws.
  - ▶ Tighten screws with a maximum torque of 1.1 Nm.
  - ▶ The screw must not deform the mounting flange during tightening.
- ▶ Place and position the SC4 (B), then install it with the recommended screws. The screw head must not deform the mounting flange (B).
- ▶ Place cover ring (A) with groove (D) downward and press close to the button surface. The cover ring must be flush with the entire button surface.

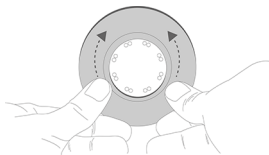

### NOTICE

#### Mineral grease and oils can attack the plastic of the button!

- ▶ Do not use grease or oils to apply the cover ring (A).

### NOTICE

The SC4 is not short circuit-proof and can be damaged if connected incorrectly.

- ▶ Before applying the operating voltage, check to ensure correct connection.

## 5.5 Connecting SC4 to the safety relay

1. Connect SC4A and the SC4B to the safety relay of the SC4A (M8).
2. Connect the SCA4A and SC4B to the safety relay based on the following connection diagram.

### 5.5.1 MCR-225 connection plan

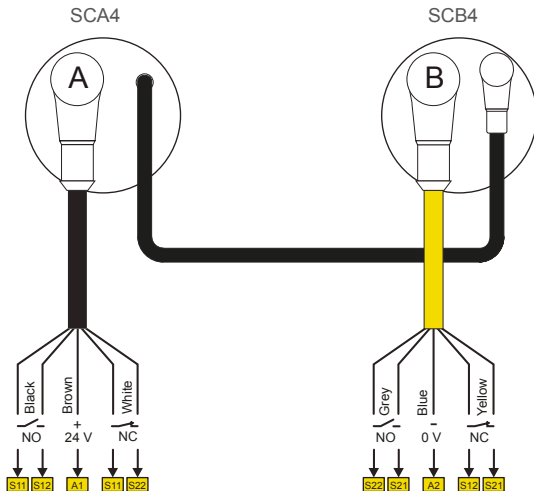

### 5.5.2 Connecting SC4 to a spare safety relay

The SC4 can also be connected to another safety relay or integrated in an SRP/CS and must be coordinated with CAPTRON Electronic GmbH. The safety of the system in which the SC4 is integrated is the responsibility of the operator. For more information, please refer to [sales@captron.com](mailto:sales@captron.com).

## 5.6 Testing the safety function of the SC4

To ensure the safety function of the SC4, test the safety function as follows.

- During initial start-up
- Once the testing interval has expired
- After maintenance and repairs

Record the results.

- ▶ Disconnect SC4 from the machine.
- ▶ Connect a meter to the contacts of the safety relay that release the machine function.
- ▶ Actuate the SC4s one after another.
- ✓ LEDs must be lit red.
- ✓ The safety relay must not release N/O or N/C contacts.  
Switching on must be verified at the output contacts of the safety relay using the meter and must not exceed the safety times (0.5 s in this case).
- ▶ Disconnect the SC4 from the power supply.
- ▶ Actuate and continue actuating the SC4.
- ▶ Restore the power supply.
- ✓ LEDs must be lit red.
- ✓ The safety relay must not release N/O or N/C contacts.

## 6 Maintenance

### 6.1 Maintenance operations

Carry out the following maintenance operations at the specified intervals.

Maintenance operation	as needed	annually	Testing interval
Clean the button surface	X		
Test the safety function			X
Check cables for intactness and firm fit		X	
Check screw connections for tightness		X	

## 7 Disposal

Different types of electrical and electronic components must be recycled according to their type. All applicable statutory, state and local laws and regulations must be complied with.

## 8 Technical specifications

General data SC4	
Sensor principle	capacitive static-dynamic
Temperature range	0°C to +55°C (+32°F to +131°F)
Rated insulation voltage	300 V
Degree of contamination	3
Degree of protection	IP 67
Housing material safeCAP	Polycarbonate (PC)
Static discharge	8 kV EN 61 000-4-2
High-frequency radiation	10 V/m EN 61 000-4-3
Fast transients	2 kV EN 61 000-4-4
HF conducted	10 V EN 61 000-4-6
Radio interference class	B EN 55 011

Output SC4	
Contact configuration	1 NO, 1 NC
Relay type	Electronic PhotoMOS relay
Minimum current	10 mA per contact
Switching capacity at 24 V	200 mA per contact
Reliability	Semi-conductor level

Input SC4	
Operating voltage	24 V DC $\pm$ 1.10%
Ripple	max. 10%
Power consumption	< 65 mA

Input SC4	
Switching frequency	1 Hz
Actuation speed	> 50 mm/s

## 8.1 Technical specifications, safety relay MCR-225

General data	
Wire cross-section	0.2 - 2.5 mm <sup>2</sup>
Operating temperature	- 25 to + 55 °C
Storage temperature	- 25 to + 85 °C
Switching capacity	NO 3 A / 230 V AC (AC 15) NC 1 A / 230 V AC (AC 15) NO 1 A / 24 V DC (DC 13) NC 1 A / 24 V DC (DC 13)
Resistance to short circuit Max. safety fuse Circuit breaker	6 A gL C 8 A

Safety figures	Value	Unit
Category	4	
PL	e	
MTTF <sub>d</sub>	90	a, years
DC <sub>avg</sub>	99.0	[%]
PFH <sub>d</sub>	7.77 e-9	[1/h]
average usage d <sub>op</sub>	220	[days/year]
average usage h <sub>op</sub>	12	[hours/day]
t <sub>cycle</sub>	140	[s/cycle]
Lifetime	20	years
Test Time Interval	1	months

## TIP

Refer to the safety relay instructions for more technical specifications.

## 8.2 Dimensional drawing

### 8.2.1 SC4A

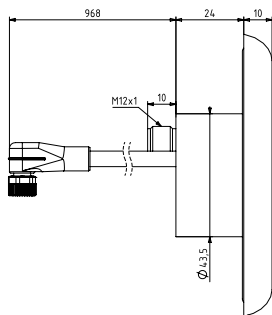
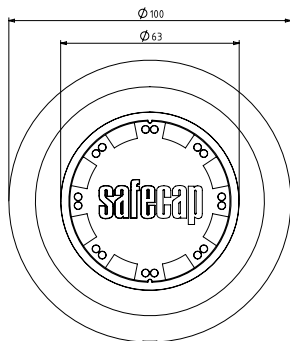

## 8.2.2 SC4B

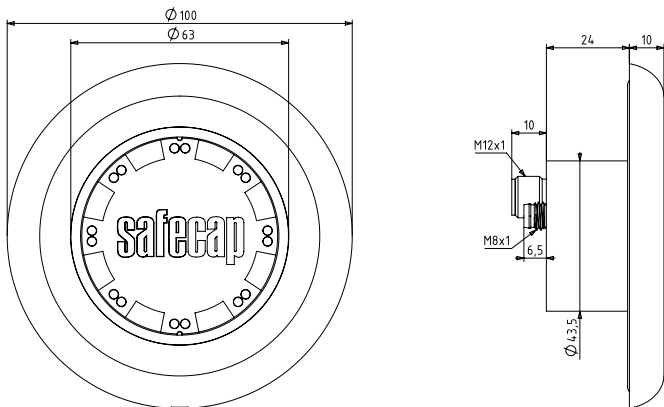

## 9 Declaration of conformity

CAPTRON

CAPTRON Electronic GmbH  
Johann-G.-Gutenberg-Str.7  
82140 Olching, Germany  
www.captron.com

### EU-Konformitätserklärung EU Declaration of Conformity

Verantwortlich als Hersteller: **CAPTRON Electronic GmbH**  
*Responsible manufacturer:* Johann-G.-Gutenberg-Str. 7  
D-82140 Olching

Dokumentationsbevollmächtigter: **CAPTRON Electronic GmbH**  
*Authorised representative for documentation:* Johann-G.-Gutenberg-Str. 7  
D-82140 Olching

erklärt, dass das Produkt: **SENSORtaster safeCAP SC4 A+B mit Zweihand-Sicherheitsrelais PNOZ s6**  
*declares that the product:* **SENSORswitch safeCAP SC4 A+B with two-hand safety relay PNOZ s6**

Verwendungszweck: **Sicherheitsbauteil / kapazitive Zweihandschaltung**  
*Intended purpose:* **Safety device / capacitive two-hand safety control**

den grundlegenden Anforderungen der Richtlinien:  
*complies with the essential requirements of the directives:*  
2006/42/EG Maschinenrichtlinie  
2014/30/EU EMV-Richtlinie  
2011/65/EU RoHS-Richtlinie

Die Schutzziele der Niederspannungsrichtlinie wurden gemäß Anhang I, Nr. 1.5.1 der Maschinenrichtlinie eingehalten.

gemäß den nachfolgend aufgeführten harmonisierten Normen entspricht.  
*in accordance with harmonised standards below.*  
DIN EN ISO 13849-1:2023-12  
DIN EN ISO 13851: 2019-11  
DIN EN 60947-5-1: 2018-03

Benannte Zertifizierung-Stelle: DGVU Test Prüf- und Zertifizierungsstelle Elektrotechnik  
*Named certificate authority:* Fachbereich Energie Textil Elektro Medienerzeugnisse  
Gustav-Heinemann-Ufer 130  
D-50968 Köln  
Benannte Stelle der EU, Kennnummer: 0340

EG-Baumusterprüfbescheinigung Nr.: ET 26005  
*EC-Type Examination Certificate No:*

Olching, den 11.03.2026



Kilian Hüttenhofer  
Head of Electrical Engineering

Tel +49 8142 - 4488-0 • info@captron.com  
Geschäftsführer: Philipp Balm, Albrecht Hohenadl • München HRB 70962 • USt-ID Nr.: DE 129 310 850

QUALITY MADE IN BAVARIA

1

## 10 Imprint

The operating instructions have been authored and published by

CAPTRON Electronic GmbH

Johann-G.-Gutenberg-Straße 7

82140 Olching – Germany

Tel +49 (0) 8142 - 44 88 – 160

[sales@captron.com](mailto:sales@captron.com)

[www.captron.com](http://www.captron.com)

Copyright 2020



03.03.2026